

DIGITAL VARIABLE AREA FLOWMETER

MODEL NO.: SC/R-300/D



INSTRUCTION & MAINTAINANCE MANUAL

⚠ CAUTION

Users are advised to strictly follow the Installation & Operating Instructions provided by **Spink Controls**. Failure to comply may result in personal injury and/or damage to the instrument. **Manufacturer** shall not be held responsible for any consequences arising from improper installation, operation, or maintenance.

⚠ WARNING

All **Spink Controls** instruments are designed to operate within the specified pressure and temperature limits. Exceeding these limits may lead to equipment failure or unsafe conditions.

Prior to installation and commissioning, carefully review the Instruction Manual. Proper handling and storage guidelines must also be followed when the instrument is not in service.

TABLE OF CONTENTS

Sections	Contents	Page No.
Section 1	Handling, Unpacking & Storage Guidelines	3
	1.1 Unpacking & Handling	
	1.2 Storage & Preservation	
Section 2	Overview	3
	2.1 Features	
	2.2 Working Principle	
Section 3	Technical Specification	4
	3.1 Standard Technical details	
	3.2 Special Case	
	3.3 Flow Chart	
	3.4 Model Specifications	
Section 4	Installation	7
	4.1 Installation Guidelines	
	4.2 Important Points for Flowmeter Installation	
Section 5	Electrical connections	10
Section 6	Programming Of Microprocessor Based Controller	10
	6.1 For Model R-300D-2 (Totalizer)	
	6.2 For Model R-300D-3 (Batch Controller)	
Section 7	Testing & Calibration	12
Section 8	Constructions	13
Section 9	Maintenance & Troubleshooting	14
	9.1 Maintenance Guidelines	
	9.2 Troubleshooting Guide	
Section 10	Manufacturer Details	15

Section 1: Handling, Unpacking & Storage Guidelines

1.1 – Unpacking & Handling:

- Inspect package for damage before opening.
- Follow all package markings and instructions.
- Unpack in a clean, dry area using proper tools.
- Handle carefully; avoid shock, impact, or stress on indicator.
- Do not lift by housing, cable glands, or display—use main body only.
- Verify contents with delivery note; report shortages/damage immediately.
- Retain original packing for future use.
- **Spink Controls** is not responsible for damage due to improper handling/unpacking.

1.2 – Storage & Preservation:

- Store in a clean, dry, vibration-free, and non-corrosive environment.
- Protect from moisture, dust, sunlight, and harsh conditions.
- Seal cable entries to prevent moisture ingress.
- Keep flanges/threads covered with caps.
- Use original packing wherever possible.
- For long-term storage: inspect periodically and re-verify calibration before installation.

Section 2: Overview

R 300/D Model Series is a metal tube rotameter based on the variable area principle, suitable for accurate flow measurement of liquids and gases. It provides accurate digital readout with local indication.

2.1 – Features:

- Totalizing and Batch controller
- Minimum pressure loss.
- Accurate measurement even at higher flow rates (up to 200 m³/hr).
- Suitable for low flow applications (up to 10 LPH).
- Inbuilt 4–20 mA transmitter (For Model SC/R-300-02)
- No moving external assembly, resulting in low maintenance.
- Density correction facility available.

2.2 – Working Principle:

The instrument operates on the variable area principle. When fluid flows through the tapered tube, a differential pressure is created across the float, causing it to rise. As the float moves upward, the flow area increases, reducing the differential pressure until equilibrium is reached between fluid force and float weight. The float position is thus directly proportional to the flow rate (as per Bernoulli's theorem). The float movement is transmitted via magnetic detection on sensor and provides a digital readout of the flow rate.

Enables accurate **total flow measurement (totalizing)** along with **automated batch control**, ensuring precise quantity handling in process operations. This feature is particularly useful in applications requiring **controlled dosing, filling, or transfer of a fixed volume**, such as in chemical processing, water treatment, and industrial batching systems.

Section 3: Technical Specification

3.1 – Standard Technical details:

Rangeability	: 10 : 1
Accuracy	: +/- 1.5% of FSR
Repeatability	: 0.5% of FSR
Pressure Rating	: 80 bar-g (For Special Case : 250 bar-g)
Temperature Rating	: -20 to 200°C Above 200 to 350°C - Remote indication required
Connection type	: Flanged , Threaded (BSP or NPT), Sanitary fitting/ Tri clover end
Flow direction	: Bottom to Top (Rear entry if required)
Straight line requirement	: Upstream : 10D Downstream : 10D
Flow velocity	: 0.5 – 3 m/s

TRANSMITTER DETAILS

Type	: 2 /3 - wire
Power Supply	: 24 V DC -Totalizer,230 VAC – Batch Controller
Output signal	: 4 – 20 mA
Flow Display	: Digital – 4 digital LCD
Totalizer Display	: Digital – 8 digital LCD
Max. load Impedance	: 600 Ω
Power consumption	: 0.720 W

ENCLOSURE DETAILS

Material	: Die cast Aluminium epoxy coated
Cable Entry	: 1/2" NPT (M)
Certifications	: 1) Flameproof - Ex d IIB T4 IP - 67 2) PESO , SIL 2 , ATEX

3.2 – Special Case:

Remote Indication	: Above temperature of 200 & upto 350°C
Steam Jacketing	: Maintains fluid temperature for viscous or solidifying media
Float Damping	: Recommended for gas applications with fluctuating pressure
PTFE lining	: Suitable for corrosive / acidic service
Enclosure	: SS 304, SS 316,

ACCESSORIES

Magnetic Filter	: For media containing magnetic particles that may affect readings
Reducer & Enlarger	: To match flowmeter size with pipeline size
By pass type	: Allows maintenance without interrupting flow; suitable for all flow directions

3.3 – Flow Chart:

Line size NB		Flow Segment	Water (LPH)		Air (m ³ /hr) 0° C & 1 atm	Pressure Loss mm of WC
Flange connection	Tri clover TC		Material 304/316/316L	Material SS PTFE		
20 NB (¾")	1" (OD : 50.5 mm)	1A	5 – 50	3.3 – 33	0.15 – 1.5	650
		1B	10 – 100	6.5 – 65	0.3 – 3	720
		1C	20 – 200	13 – 130	0.6 – 6	
		1D	30 – 300	20 – 200	0.9 – 9	
		1E	40 – 400	26 – 260	1.2 – 12	
		1F	50 – 500	32.5 – 325	1.5 – 15	
		1G	60 – 600	40 – 400	1.8 – 18	
25 NB (1")	1" (OD : 50.5 mm)	2A	80 – 800	52 – 520	2.4 – 24	790
		2B	100 – 1000	65 – 650	3 – 30	950
		2C	120 – 1200	78 – 780	3.6 – 36	
		2D	160 – 1600	104 – 1040	4.8 – 48	
	2" (OD : 64.0 mm)	2E	200 – 2000	130 – 1300	6 – 60	1050
		2F	250 – 2500	143 – 1430	7.5 – 75	
		2G	300 – 3000	195 – 1950	9 – 90	
2" (OD : 64.0 mm)	2H	350 – 3500	227 – 2275	10.5 – 105		
	2I	400 – 4000	260 – 2600	12 – 120		
40 NB (1.5")	2 ½" (OD : 77.5 mm)	3A	500 – 5000	325 – 3250	15 – 150	
		3B	600 – 6000	390 – 3900	18 – 180	
50 NB (2")	3" (OD : 91 mm)	3C	750 – 7500	490 – 4900	22.5 – 225	980
		3D	1000 - 10000	650 – 6500	30 – 300	
80 NB (3")	4" (OD : 119 mm)	4A	1500 – 15000	900 – 9000	45 – 450	1000
		4B	2000 – 20000	1300 – 13000	60 – 600	
		5A	2500 – 25000	1600 – 16000	75 – 750	
100 NB (4")	6" (OD : 166.1 mm)	5B	3000 – 30000	1900 – 19000	90 – 900	1200
		5C	4000 – 40000	2600 – 26000	120 – 1200	
		6A	5000 – 50000	3200 – 32000	150 – 1500	
125 NB (5")	NO TC	6B	6000 – 60000	3900 – 39000	180 – 1800	1200
		6C	8000 – 80000	5200 – 52000	240 – 2400	
150 NB (6")	NO TC	7A	10000 – 100000	6500 – 65000	300 – 3000	1200
		7B	12000 – 120000	7800 – 78000	360 – 3600	
		8A	15000 – 150000	9700 – 97000	450 – 4500	

3.4 – Model Coding :

Suffix Code	1	2	3	4	5	6	7	8	9	10	Description
Model	SC/R- 300/D										Digital Indication
Variants for Digital Indication		1									Digital Display with loop powered 4 – 20 mA output
		2									Totalizer with loop powered transmitter
		3									Totalizer & Batch controller – 230 VAC
		4									High and Low Switch
		5									Totalizer and Density correction Facility
Flow Range		XX									Refer the Flow Range Chart
Fluid			L								Liquid
			G								Gas
Material Wetted Parts				S4							Body & Float SS 304
				S6							Body & Float SS 316
				ST							Body & Float PTFE Lined
				SL							Body & Float SS 316L
				XX							Other on Request
Connection					F						Flanged ANSI /BS/DIN
					S						Screwed NPT/BSP (M/F)
					T						Tri-Clamp
Flange to flange						1					300 mm
						2					250 mm
						3					400 mm
						4					500 mm
Enclosure							EX				Die-cast Aluminum Ex d IIB T4 IP 67
							WP				Die-cast Aluminum IP 68 (Non - battery)
Remote Indication								RM			Required (Above 150 Deg.C)
								RX			Not Required
Accessories									J		Steam Jacketing

For Eg. : SC/R-300/D – 2 – 2D – L – S6 – F – 1 – EX – RX – XX

Section 4: Installation

Note:

- Inspect the instrument upon receipt for any transit damage. Report immediately to the **Spink Controls** service department if any issue is observed.
- Refer to Section 1 (Handling & Storage) before installation.
- Installation, commissioning, and maintenance must be carried out only by trained and authorized personnel who have read and understood this manual.

4.1 – Installation Guidelines

- Ensure the float is free before installation; check and tighten the float retainer if required.
- Install the flowmeter strictly in **vertical position** with **inlet at bottom and outlet at top**.
- Maximum deviation from vertical should not exceed 1° (use plumb-bob).
- Maintain minimum **10D upstream** and **10D downstream** straight pipe length (D = pipe diameter).
- Provide isolating valves at inlet, outlet, and bypass line for maintenance.

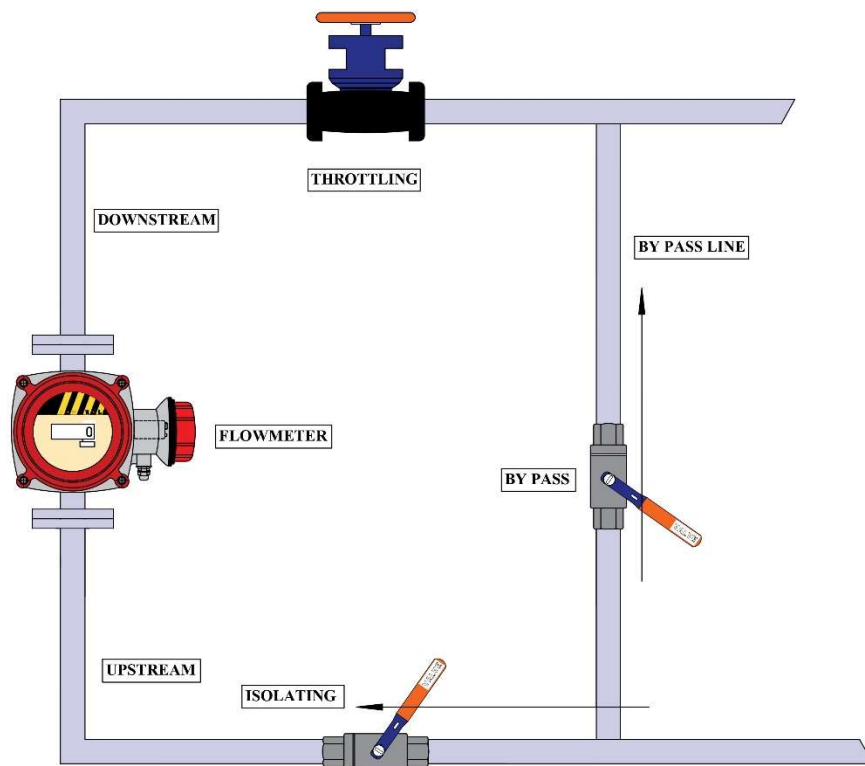

Fig. No.: 4.1 – Installation diagram

4.1.a. For By – Pass application:

- Verify model selection as per flow direction (refer Fig. No.: 4.2).
- Install Orifice Plate Assembly (Orifice plate is sandwiched between gasket and then carrier rings) between flanges in the main pipeline as per the arrow marked on the body.
- Connect bypass line:
 - Bypass Piping (SS316 / MS): Ensure straight, rigid connections.
 - PU Tubing: Ensure kink-free, leak-proof connections with proper ferrule fittings.
- Mount Rotameter vertically (for Bottom-to-Top) or horizontally (for Left-to-Right /Right-to-Left).
- Ensure sufficient clearance for reading and maintenance.
- Ensure Rotameter is place exact 90°.

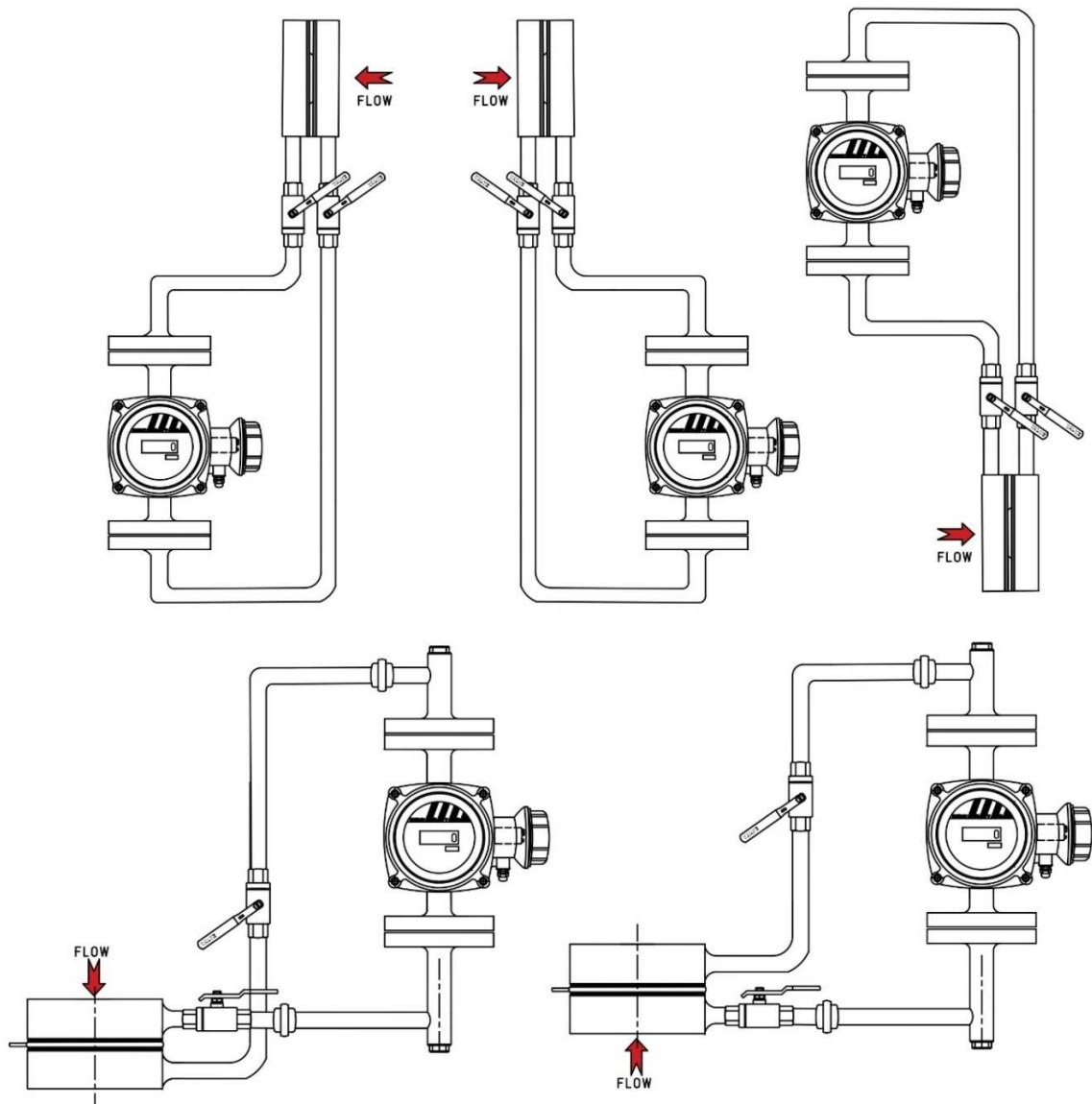

Fig No.: 4.2 – By pass type Flowmeter types

4.1.b. For Steam Jacketing

Firstly, follow installation steps as per Section 4.1, then proceed:

- Provide **steam inlet at bottom & outlet at top** with continuous flow.
- Ensure all connections leak-proof.

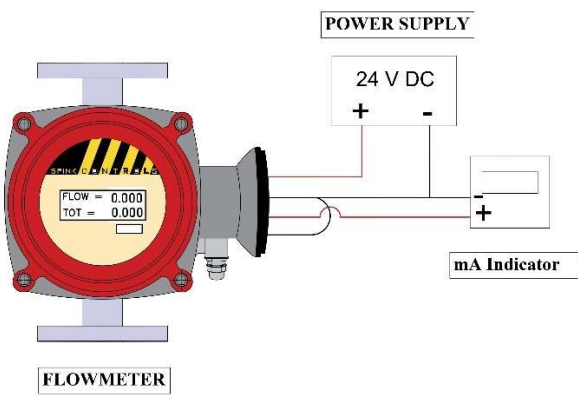

Fig No.: 4.2 – Steam jacketing type Flowmeter

4.2 – Important Points for Flowmeter Installation

1. **Straight Pipe Length:** Adequate straight pipe length should be maintained upstream and downstream to ensure stable and accurate readings.
2. **Strainer:** A strainer is not always mandatory; however, it is recommended where dust or foreign particles may be present, as it improves protection and ease of maintenance.
3. **Bypass Piping:** It is recommended to provide a bypass line for safety and to facilitate maintenance without interrupting the process flow.
4. **Valve Operation:** The flow control valve should be operated gradually while observing the flow indication. Starting or stopping the pump with the valve fully open may cause sudden fluid impact on internal parts, leading to possible damage. Ensure no air is trapped in the pipeline, as residual air can increase shock effects.
5. **Valve Positioning:** For gas applications, outlet-side control helps maintain stable internal pressure and ensures accurate measurement.

Section 5: Electrical Connections



Electrical Connection of Totalizer
Figure 5.2.a

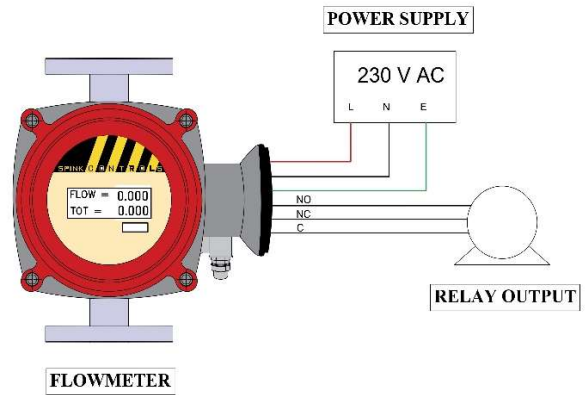

Electrical Connection of Batch controller
Figure 5.2.b

Section 6: PROGRAMMING OF MICROPROCESSOR BASED CONTROLLER

This flow meter has the 16 digit X 4 lines LCD display to indicate the **FLOW RATE, BATCH SETTING, BATCH FILLED AND TOTALISER, DENSITY CORRECTION.**

The flow meter has four keys the **“SET”, “INC”, “SHIFT”, and “SAVE/EXIT”**

SET	BUTTON FOR PROGRAMMING
INC	INCREMENT THE PARAMETER VALUE
SHIFT	TO SHIFT THE PARAMETER VALUE
SAVE/EXIT	TO SAVE AND EXIT FROM THE PROGRAMMER.

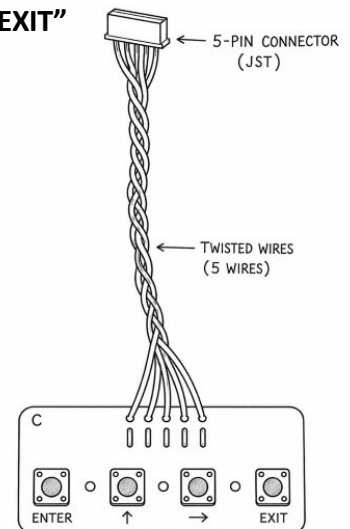

Fig.6.Keypad

6.1 – For Model R-300D/2 (Totalizer):

1.The totalized value can be reset using the RESET key

2. Density Setting (SET DENSITY) :-

- Press SET → Display shows: “SET DENSITY”
- Default value: 1.00 (calibrated with water)
- Adjustable range: 0.6 to 1.5
- Modify using INC and SHIFT
- Press EXIT/SAVE to confirm

6.2 – For Model R-300D/3 (Batch Controller):

Initial Display

On powering the flow meter, all parameters are displayed on the screen.

1. Batch Setting (BATCH SET):-

- Press SET → Display shows: “SET BATCH” (0000)
- Adjust value using:
 - INC → Increment value
 - SHIFT → Move cursor
- Press EXIT/SAVE to store and exit

2. Password Setting :-

- Press SET → Display shows: “ENTER PASSWORD” (0000)
- Default password: 8642
- Modify using INC and SHIFT
- Press EXIT/SAVE to store changes

3. Density Setting (SET DENSITY) :-

- Press SET → Display shows: “SET DENSITY”
- Default value: 1.00 (calibrated with water)
- Adjustable range: 0.6 to 1.5
- Modify using INC and SHIFT
- Press EXIT/SAVE to confirm

4. Totaliser Setting (SET TOTALISER) :-

- Display shows: “SET TOTALISER” (00000000)
- Set initial totaliser value using INC and SHIFT

Example:

- If set to 00005000 → Totaliser starts counting from 5000
- If set to 00000000 → Starts from zero
- Press EXIT/SAVE to store

5. Factory Setting (Restricted Access)

- Press SET → Display shows: “ENTER PASSWORD2”
- This is for factory settings
- **⚠ Do not modify these settings.**

6. Batch Reset Function

- In normal mode, press SHIFT
→ Batch resets to 0000

7. START / STOP Batch Operation

- **In normal mode:**
 - EXIT/SAVE → Starts or stops the batch
- **In setting mode:**
 - EXIT/SAVE → Saves entered values

8. Memory Function

All parameters are stored in non-volatile memory, ensuring:

- No data loss during power failure
- Settings remain intact after restart

Note

- **This model does not include a transmitter.**

Section 7: Testing & Calibration

Each flowmeter is tested for hydrostatic and temperature conditions, followed by precise calibration.

Calibration Method

Service conditions such as flow range, pressure, temperature, density, and viscosity are first considered to determine the **water equivalent** for accurate calibration. Calibration is performed using water at various flow rates, with real-time monitoring of temperature and pressure to ensure high accuracy.

All calibration tests are conducted in accordance with **ISA RP 16.6 standards**. A **Calibration & Test Report** is provided with every instrument.

7.1. – Gravimetric Method:

Flow is calibrated by measuring the mass of collected liquid over time. For gases and liquids, water equivalent is calculated using operating parameters via **Spink Controls** software.

Calibration is carried out at multiple flow rates using calibrated tanks and high-precision timing.

7.2. – Comparison Calibration Method:

Calibration is carried out by comparing the flowmeter output with a calibrated reference (master meter) under identical conditions.

Recalibration is recommended annually to maintain accuracy and performance.

Section 8: Construction

Part No.	Item Name
1	Float
2	Stopper
3	Circlip

7.a – Below 10 m³/hr

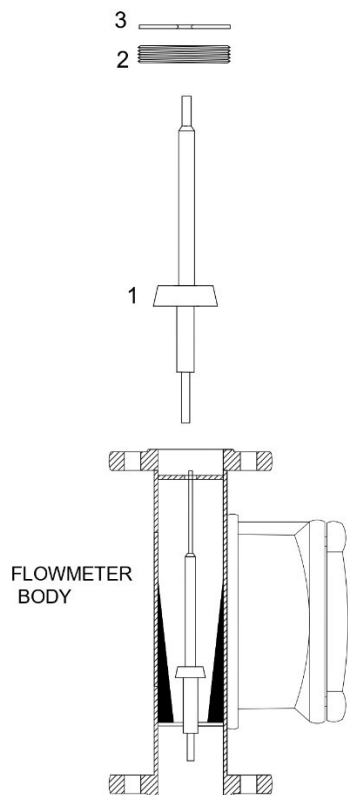

Figure no.8.1

7.b – Above 10 m³/hr & Dampening Flow

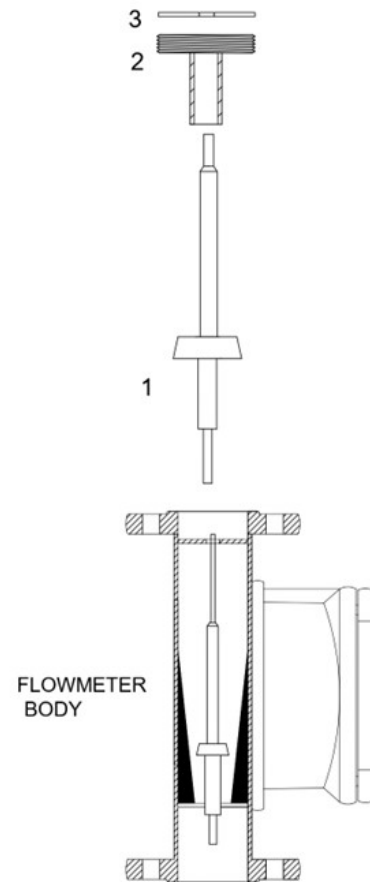

Figure no.8.2

Section 9: Maintenance & Troubleshooting

9.1 – Maintenance Guidelines:

- The instrument requires minimal maintenance, as there are no moving parts except the float.
- Periodic cleaning or flushing of the metering tube is recommended to remove any foreign particles or deposits that may affect performance.
- If a strainer is installed at the inlet, it should be cleaned regularly.
- Operate the flowmeter within specified pressure and temperature limits to ensure long service life.
- During dismantling and reassembly, refer to Figures 8.1 & 8.2 to ensure correct assembly.
- For configuration or setting-related issues, refer to Section 5 of this manual.

9.2 – Troubleshooting Guide:

Sr. No.	Observation	Possible Cause	Corrective Action
1	Reading correct but float stuck	Float damaged or corroded	Inspect and replace float (especially for gas service)
3	Reading drifts higher over time	Scaling / deposition on float or tube	1.Clean metering tube and float 2.If magnetic particles are present, add magnetic strainer in line with flowmeter
4	Float fluctuation	Incorrect / unstable operating pressure	Maintain pressure as per design specifications

Section 10: Manufacturer Details

SPINK CONTROLS

Office Address : 303, Siddharth Towers,
G.P. pai road, Kopri, Thane (E) - 400603

Plant 1 : Gala No.F-4, A- Wing, Udyog Bhavan No.-2,
Plot No.K-3, Additional Ambernath Industrial Area,
near Anand Nagar, MIDC., Ambernath, Dist. Thane - 421 506.

Plant 2 : Plot No. : MS 114/115, Ambernath Industrial Area ,
Chikhloli MIDC , Ambernath(W) , Thane :421501

Contact : info@spinkcontrolsindia.com

Website : www.spinkcontrols.com , www.spinkcontrolsindia.com